

Schema regolazione tenditori serie TN400

Adjusting scheme wardrobe adjusters TN400 series

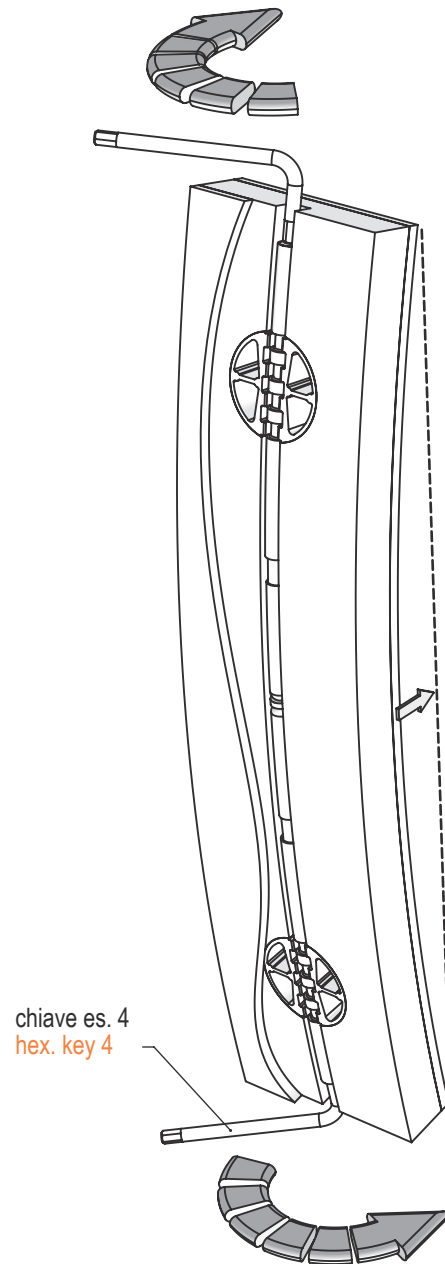

TN404



Tenditore a scomparsa tipo TN401 TN403 TN404

Hidden wardrobe adjuster TN401 TN403 TN404 type

NORMALMENTE UTILIZZATI SU PANNELLI DI TAMBURATO. SPESSORE MINIMO 18-20 A SECONDA DELLO SPESSORE DELLA COPERTURA VEDI FIG. 1. REGOLAZIONE SINGOLA E DOPIA. INTERASSE MIN. 1200 MAX. 2800.

NORMALLY USED ON HOLLOW WOOD PANELS. MINIMUM THICKNESS 18-20, DEPENDING ON THE THICKNESS OF THE COVER, SEE FIG. 1 SINGLE AND DOUBLE ADJUSTMENT. CENTRE DISTANCE: MINIMUM 1200 MAXIMUM 2800



acciaio - zama
steel - die-cast

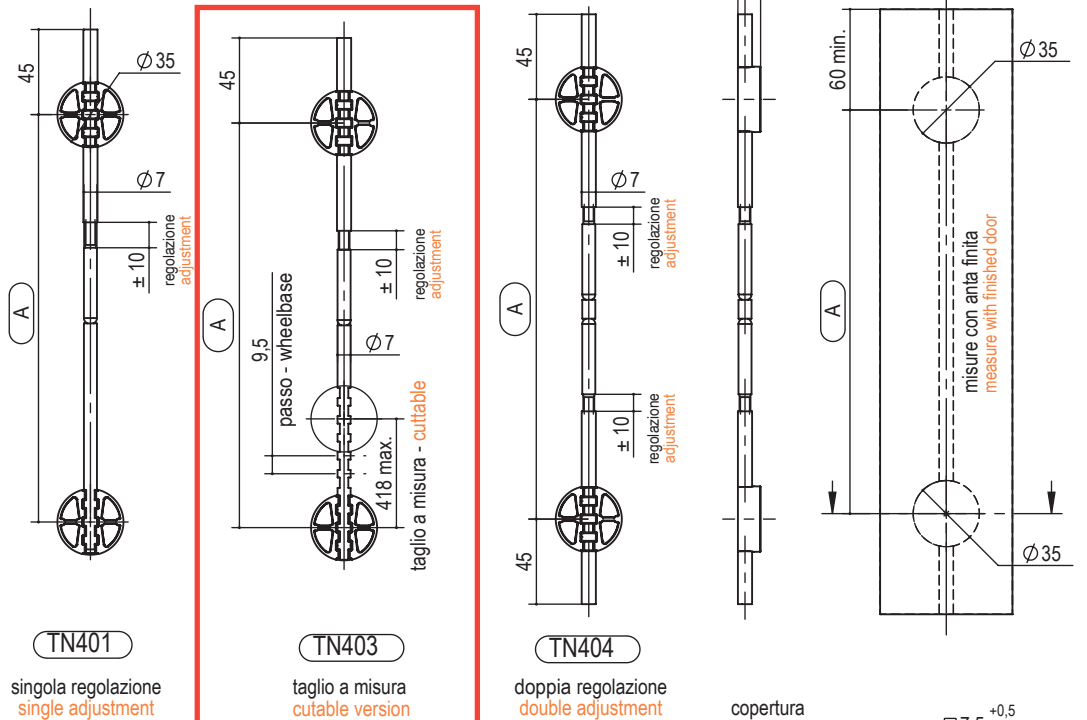
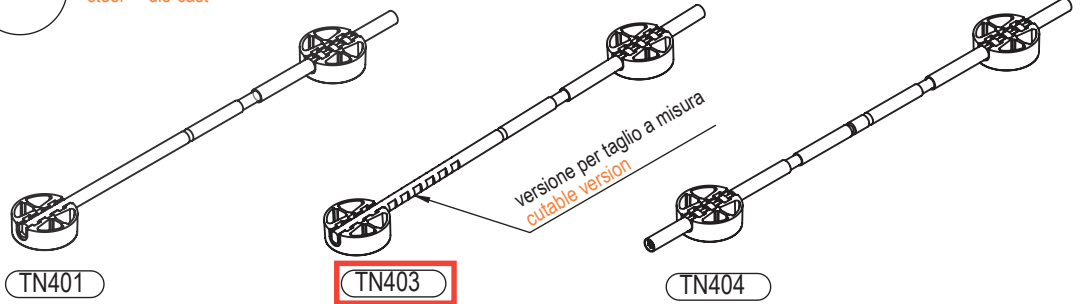

test indicativi su pannello agglomerato 2500x400x20
indicative test on chipboard panel 2500x400x20

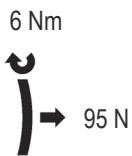

test indicativi su pannello agglomerato 2500x400x28
indicative test on chipboard panel 2500x400x28

tipo type	misura measure	A	finitura finishing	box	kg / box
TN401. TN404.	1700.	1700	00 grezzo raw	25	14,6
	2010.	2010			16,6
	2300.	2300			18,6
	2450.	2450			19,7
	2610.	2610			20,9
	2760.	2760			22
tipo type	misura measure	A	finitura finishing	box	kg / box
TN403.	1900.	1900	00 grezzo raw	25	16,8
	2610.	2610			18,6
	2300.	2300			20,9
	2800.	2800			21,8

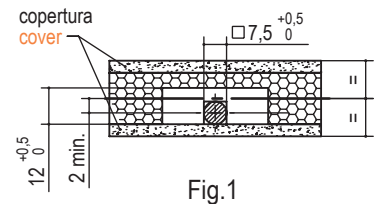



Tenditore alluminio Aluminium wardrobe adjuster

I TENDITORI DELLA SERIE ST720 SONO STATI INIZIALMENTE PROGETTATI PER ANTE BATTENTI.

CARATTERISTICHE FONDAMENTALI:
NON GENERA AUTOTENSIONE CON L'ANTA ESSENDO IL MONTAGGIO NON VINCOLATO CON VITI.
OTTIMO RAPPORTO QUALITA' PREZZO.
SENZA FORI E SENZA VITI.
OTTIMO IMPATTO ESTETICO.
VELOCITA' DI MONTAGGIO.
ADATTO PER AMBIENTI CON UMDITA' VARIABILE TIPO CUCINE.

ST720 SERIES TENSIONERS WERE ORIGINALLY DESIGNED FOR SWING DOORS.

KEY FEATURES:
NO SELF-TENSIONING WITH THE DOOR SINCE THE MOUNTING IS NOT CONSTRAINED WITH SCREWS.
GREAT VALUE FOR MONEY.
UNDRILLED AND WITHOUT SCREWS.
GREAT AESTHETIC IMPACT.
FAST ASSEMBLY.
SUITABLE FOR ENVIRONMENTS LIKE KITCHENS WITH VARIABLE HUMIDITY.

Serie ST720 ST720 Series

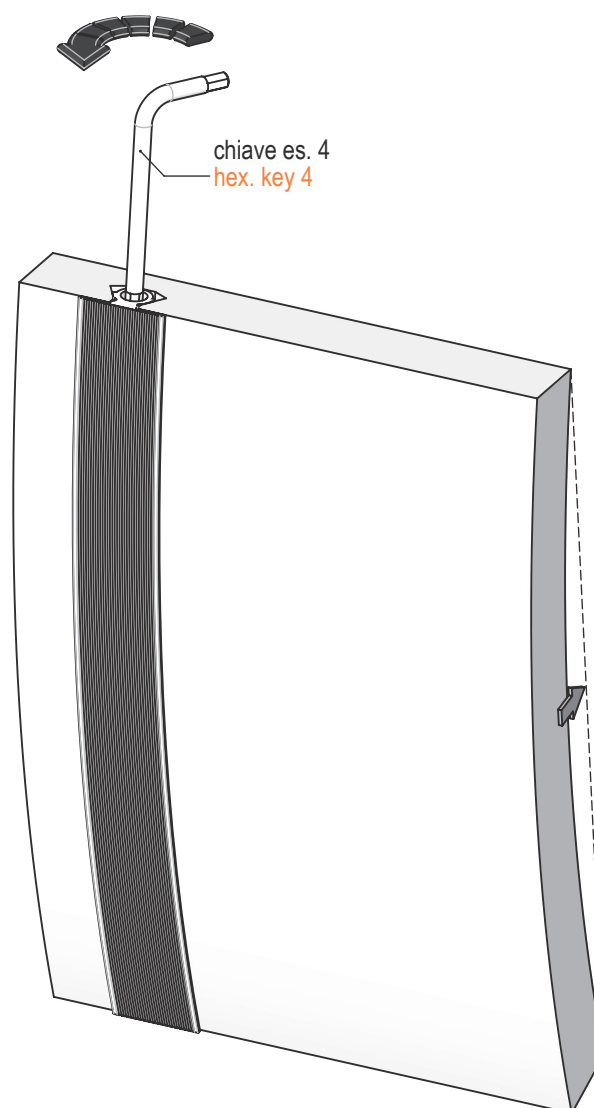



Tenditore alluminio tipo ST721 Aluminium wardrobe adjuster ST721 type

FISSAGGIO SENZA VITI
DENSITA' LINEARE 805
g/m
LUNGHEZZA: MIN 1200
MAX 2800
L'ASSENZA DI VITI EVITA
LA FORMAZIONE DI
FORZE DI AUTO
TENSIONAMENTO.

SCREWLESS FIXING
LINEAR DENSITY 805 g/m
LENGTH: MIN 1200 MAX
2800.
THE ABSENCE OF
SCREWS PREVENTS THE
FORMATION OF SELF-
TENSIONING FORCES.

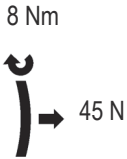

test indicativo su
lunghezza 2580
indicative test on
2580 length



fermo di posizione
stop device cover
Cod.: P.A372.00

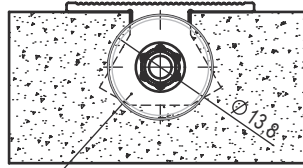
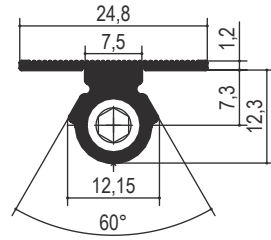

A) fermo di posizione a richiesta
A) stop-device position on demand

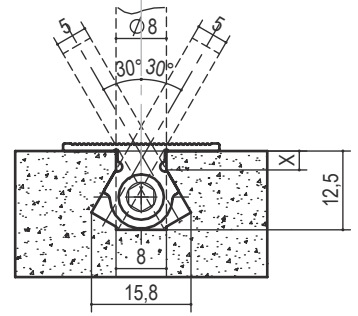

lavorazione con 3 frese a
disco in linea. DXF a richiesta.
3 in line milling operations
DXF on request.

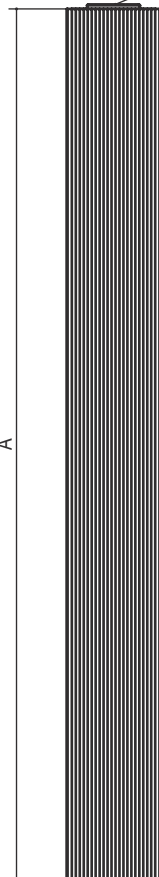

2 regolazioni - 2 adjustment



B) foro per vite
posizione a
richiesta
B) position
screw on
demand

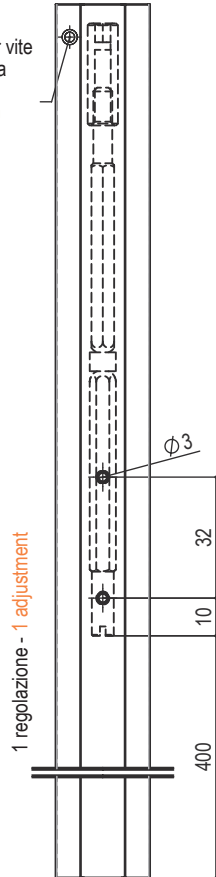

1 regolazione - 1 adjustment

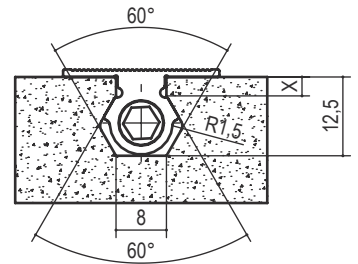

lavorazione con fresa in
sagoma. DXF a richiesta.
in shape milling operation
DXF on request

X= 3 per finitura anodizzato
X= 2.5 per finitura verniciato
X=3 for anodised finishing
X=2.5 for painted finishing

tagliabile - cuttable

tipo type	misura measure	finitura finishing	tagliabile cuttable
ST721	A a richiesta on request	00 grezzo - crude 12 anodizzato ARC - anodised altre finiture a richiesta - other finishings on request	TG

es./e.g.: ST721.A.00
es. codice tagliabile/e.g. cuttable code: ST721.A.00.TG